

# INT280-60®



## INT280-60®



INT280-60

### Application

The INT280-60 is a further development of the reliable KRIWAN oil level regulators.

The oil level regulator INT280-60 monitors and controls the oil level in the refrigerant compressors. The problem of poor oil distribution in multi-compressor packs has been overcome by actively supplying oil from the oil reservoir. This minimizes the risk of operating without enough oil in the compressor.

### Functional description

If the oil level is too low, the intelligent filling algorithm controls the oil refill. To do this, the integrated solenoid valve is opened cyclically.

The oil level regulator switches the compressor off through the internal relay if the oil level remains too low after an extended period of time. Oil refilling continues after this.

When the oil level is sufficient the relay tightens, the compressor can start again.

The reactions are time delayed, to prevent unnecessary switching in response to temporary fluctuations in the oil level.

The INT280-60 has its own monitoring system of the optical sensor. In the event of malfunctions or soiling, the relevant warning or error will be notified.

The integrated LED signals the current status.

For operation in the specified manner, the supply voltage has to be on permanently on the INT280-60.

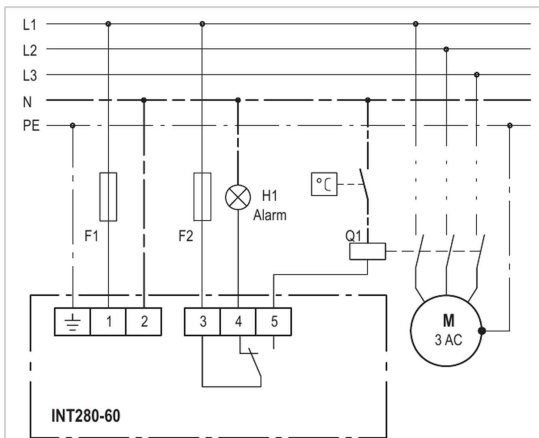

Wiring diagram

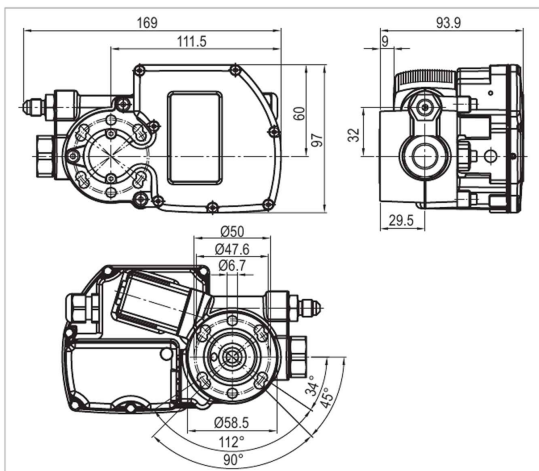

Dimensions in mm

Technical changes reserved

# INT280-60®



## INT280-60®

### Installation instructions

- Prior to installation, ensure that the O-ring at the connecting flange is seated properly.
- There must be no foreign objects in the oil infeed or outfeed area of the INT280-60.
- The device has to be mounted to the compressor horizontally. It can be rotated by 180°.
- Use matching washers for the flange fastening screws.
- Oil level regulator is pre-assembled in installation position.
- Manually screw in the screws.
- Afterwards tighten the screws alternating with a torque of 9Nm (M6, steel 8.8, dry).
- The electrical connection needs to be carried out according to the wiring diagram.
- For use at low temperatures, an oil sump heater has to be installed, to ensure trouble-free operation of the INT280-60.
- An oil filter has to be installed in the oil infeed line of the INT280-60, to prevent the solenoid valve seat from getting dirty.
- Before the refrigerating system is filled with refrigerant, the system and the connections of the INT280-60 have to be checked for leaks.

**!** The mounting, maintenance and operation are to be carried out by an electrician. The valid European and national standards for connecting electrical equipment and cooling installations have to be observed.

Connection lines that extend from the terminal box have to feature at least a basic insulation.

**!** The user has to ensure that the connections are properly tight. The electrical connection needs to be carried out according to the wiring diagram.

**!** Prior to installation, ensure that the pressure in the refrigeration circuit is and stays equal to the atmospheric pressure.

**!** The voltage supply to the INT280-60 must be switched off prior to installation/connection and the subsequent tasks.

### Flash code

The KRIWAN flash code allows for a quick and easy status display and troubleshooting.

The flash code consists of a cyclical flash sequence (red / orange or green / orange). The current status can be determined from the number of pulsing flashes.

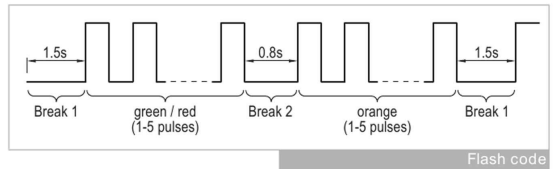

### Overview flash code

Green lit	Oil level OK
Green flashing	Oil level too low, fill
Green/Orange flashing	Warning, see below for description
Red/Orange flashing	Error, compressor is switched off; for description see table below

### Warning

1st flashing sequence (LED green)	2nd flashing sequence (LED orange)	Description
1	2	Oil level monitoring: Soiled optics, stage 1
2	1	General: Low supply voltage
	2	General: Unexpected filling behaviour identified

### Error

1st flashing sequence (LED red)	2nd flashing sequence (LED orange)	Description
1	1	Oil level monitoring: Oil level too low
	2	Oil level monitoring: Soiled optics, stage 2
	3	Oil level monitoring: Internal sensor fault
2	1	General: Supply voltage too low
	3	General: Internal alarm
	4	General: External alarm

Technical changes reserved

# INT280-60®



## INT280-60®

### Technical specifications

Supply voltage	
- 52 S 581 S026	AC 50/60Hz 230V ±10% 25VA
- 31 S 581 S026	AC 50/60Hz 24V ±10% 25VA
Permissible ambient temperature $T_A$	-30...+60°C
Permitted rel. humidity	10-95% r. h. no condensation
Medium temperature	-30...+100°C
Operating pressure	-1...+60bar
Test pressure	90bar
Differential pressure	1-25bar
Relay	
- Contact	AC 240V 2.5A C300 at least AC/DC 24V 20mA
- Mechanical service life	Approx. 1 million switching cycles
Protection class acc. to EN 60529	IP65
Supply	
- electrical	Push-in spring terminals 0.25-0.75mm <sup>2</sup>
- Oil	7/16"-20 UNF
Mounting	Flange (3-/4-hole)
Housing material	Aluminium PA glass-fibre-reinforced
Flow rate through valve	1l/min (water 20°C, 1bar differential pressure)
Permitted oils	Mineral and ester oils without additives
Permitted refrigerants	Non-corrosive, non-flammable
Mounting position	Horizontal (rotatable by 180°), ±2°
Dimensions	See dimensions in mm
Weight	Approx. 1300g
Check base	EN 61000-6-2, EN 61000-6-3 EN 61010-1 Overvoltage category II Pollution level 2

For additional technical details, see table of parameters

### Order data

INT280-60 (AC 24V)	31 S 581 S026
INT280-60 (AC 230V)	52 S 581 S026
Accessories and application information	see <a href="http://www.kriwan.com">www.kriwan.com</a>

### Table of parameters

Parameter name	Unit	Default
Filling cycle type		Fixed
Filling time	s	10
Break time	%	20
Overfill time	s	0
Oil deficiency alarm delay	s	120
Soiling stage 2		Warning